

SPECTRUM

INSTALLATION
INSTRUCTION MANUAL

TABLE OF CONTENTS

Suggested List of Tools	4
Hardware Index	5
Installation Step 1	6
INSTALLING BASE/LEGS	
Installation Step 2	7
INSTALLING LOCKERS TOGETHER	
Installation Step 3	7
FASTENING LOCKERS TO THE WALL	
Installation Step 4	8
INSTALLING FILLER STRIP and/or FINISHED PANELS	
Installation Step 5	9
INSTALLING BASE PLATES	
Installation Step 6	9
INSTALLING SLOPED TOPS (If Specified)	
Installation Step 7	10
INSTALLING Doors (If Required)	
Installation Step 8	10
INSTALLING NUMBER/ID PLATES (If Specified)	
Lockers Installed on Existing Base	10

Immediately inventory all lockers and accessories against shop drawings and room layout. Notify manufacturer immediately if you believe items may be missing.

SUGGESTED LIST OF TOOLS

Drill & drill bits

Hammer

Rubber mallet

Portable sander

Adjustable clamps with soft tips

Framing square

Level

Tape measure

T27 Torx hex Bit & driver

Hex wrenches (Allen keys)

Mitre Saw (power)

Portable Table Saw

PLEASE NOTE: You should be prepared with your personal protective equipment which can include and not restricted to safety shoes / boots, and safety glasses.

If lockers are delivered with doors attached, doors will require adjustment after lockers are set in place and fastened to each other and walls.

LIST OF HARDWARE

- ID plate — 1-½” diameter. Brushed stainless steel with black laser etched numbers. Id plates adhere to door pockets with 3M adhesive backs. SP-H-001.
- Hasp (standard) — Stainless steel hasp bar and handle preparation for users padlock. Fastened to locker body and locker door with provided stainless fasteners.
- Bar — SP-H-003.
- Handle — SP-H-002.
- Barrel nuts — #10-24 threaded unslotted stainless steel barrel nuts. SP-H-007-1.
- ⅜” screws — #10-24 T27 Tamper resistant stainless steel screws. ⅜” long. SP-H-007.
- ¼” screws — #10-24 T27 Tamper resistant stainless steel screws. ⅜” long w/ shoulder. SP-H-008.
- Hinges — Stainless steel 5 knuckle butt hinge. SP-H-009.
- T27 hex bit for tamper resistant screws. SP-H-016.

BASE

- Adjustable leg — ABS plastic adjustable leg. SP-H-005.
- Head for adjustable leg — Head for adjustable leg. SP-H-005-1.
- Screw for head — M10 screw for fastening head to base of locker. SP-H-005-2.
- Cap — White plastic cover cap used in top of M10 screw. SP-H-005-2A.
- Clip for leg — SP-H-004.
- Adhesive tab — SP-H-004-1.

STEP ONE – INSTALLING BASE/LEGS

Step 1 applies only for lockers which will not be placed on an existing base. The locker base will have holes supplied to allow the supplied 10mm screws through the bottom of the locker into the top head of the adjustable ABS legs. First, start by installing 4 ABS legs at the bottom base of the locker which will be installed first (NOTE: for the first locker **only** two extra holes must be drilled at 13/32" on the right side to be able to install the legs). The other lockers will have only 2 ABS legs to the left side (make sure to have the lip of the ABS leg exposed to the left side of locker for the next locker to sit on top). White caps are provided to cover the exposed screw heads at the interior base of the locker.

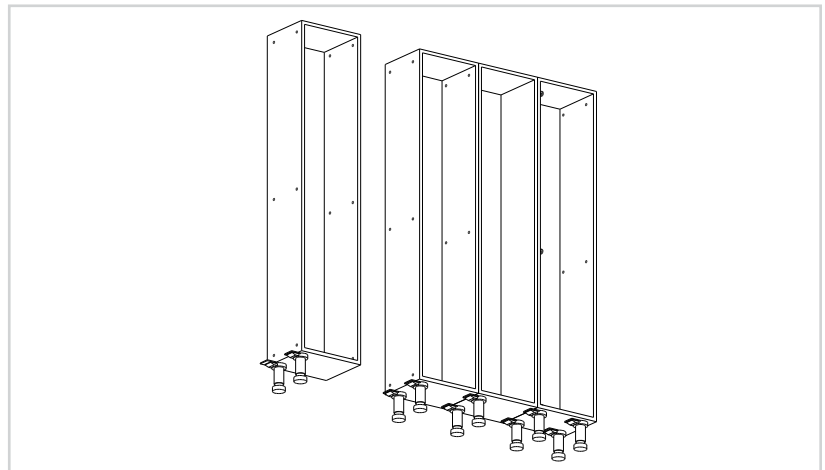
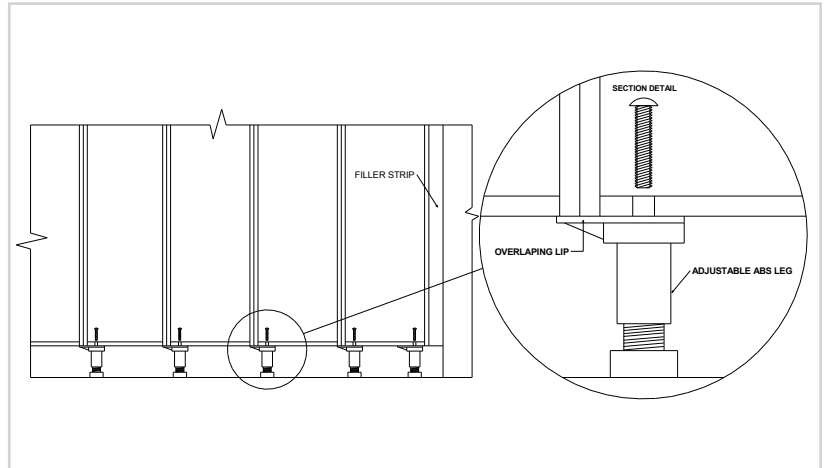

STEP TWO – INSTALLING LOCKERS TOGETHER

The interiors of the lockers will have clearance holes on the left-hand side which will allow the supplied $\frac{3}{4}$ " long 10-24 T27 Torx screw to pass through. The next locker on the left-hand side will have a threaded hole in line with the clearance hole of the locker on the right. Fasten the lockers together using all of the supplied holes and fasteners. This step is repeated for all lockers. After lockers have their base/legs established they should be set in their place next to each other. For a faster installation, attach 3 lockers together before fastening them to the wall and leveling them if necessary.

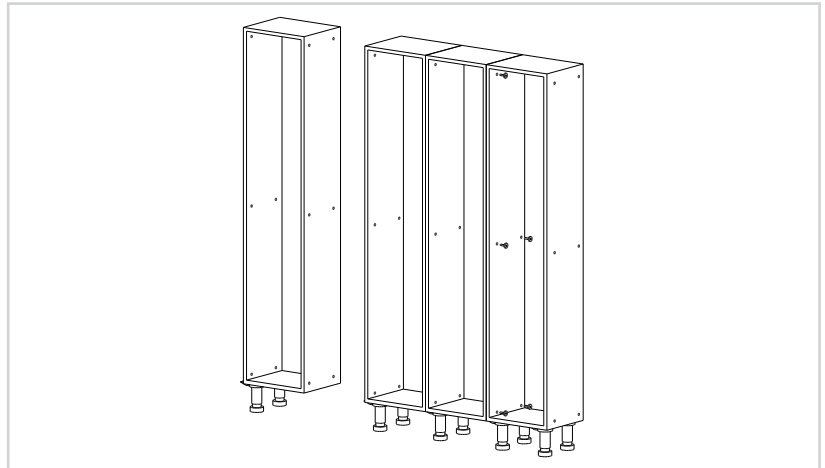

STEP THREE – FASTENING LOCKERS TO THE WALL

At least every third locker should be fastened to the wall behind the locker. Fasteners are not supplied for this due to the varying types of walls found with different projects. Fasteners should be secure to a structurally sound member such as a stud or concrete block wall.

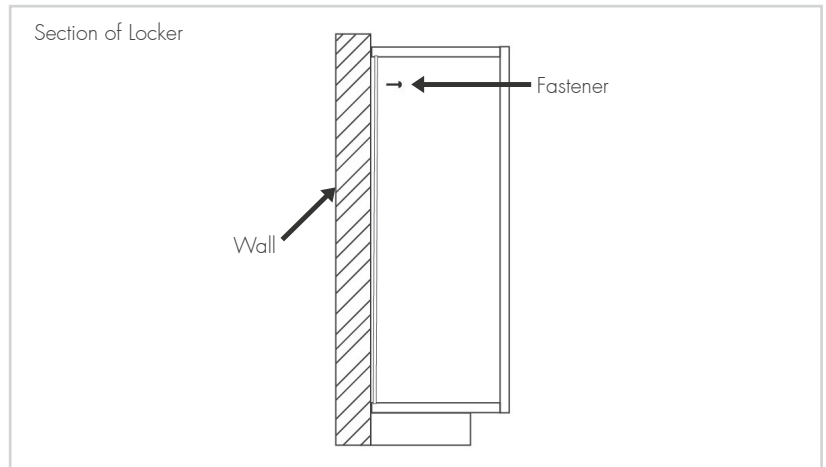

STEP FOUR – INSTALLING FILLER STRIP AND/OR FINISHED PANELS

End Filler strips (If necessary) Can be mounted directly to the locker via a screw driven through the locker body into the plane of the filler strip. Or angle brackets may be used behind the filler strips to attach. (Pilot holes are necessary when fastening screws into Phenolic material).

End finished panels can be installed by using the clearance holes on the left and right sides of the lockers.

Please note when installing a finished panel/gable to the right side of the locker, a wider hole needs to be drilled @ 9/32" to fit the screws provided.

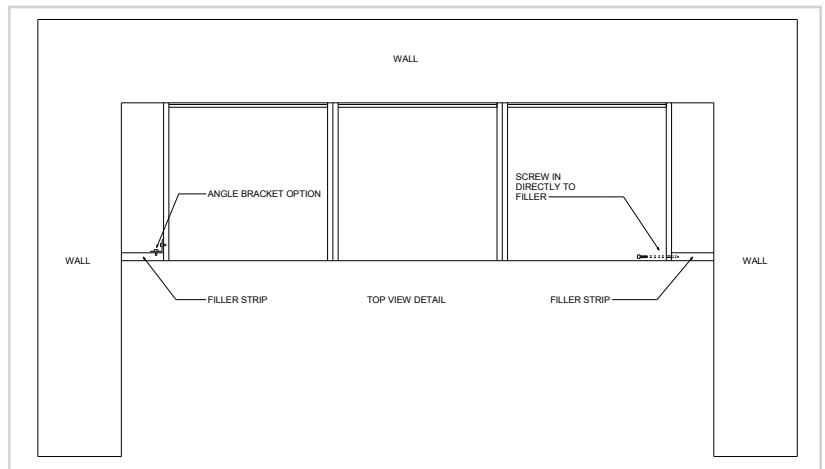
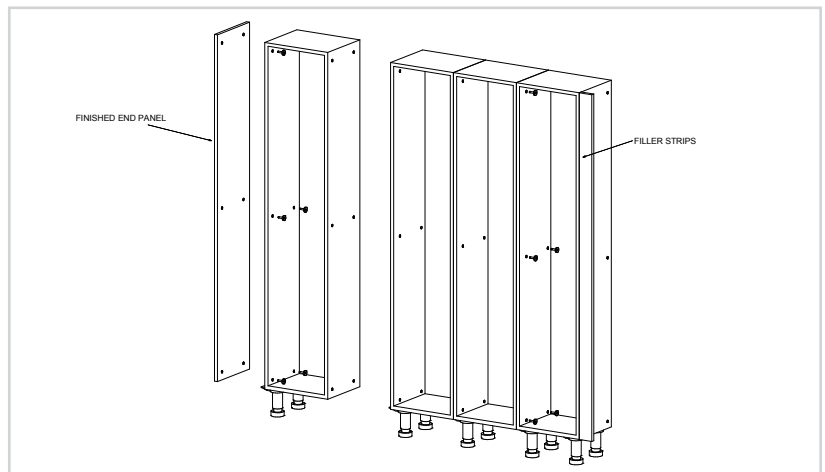
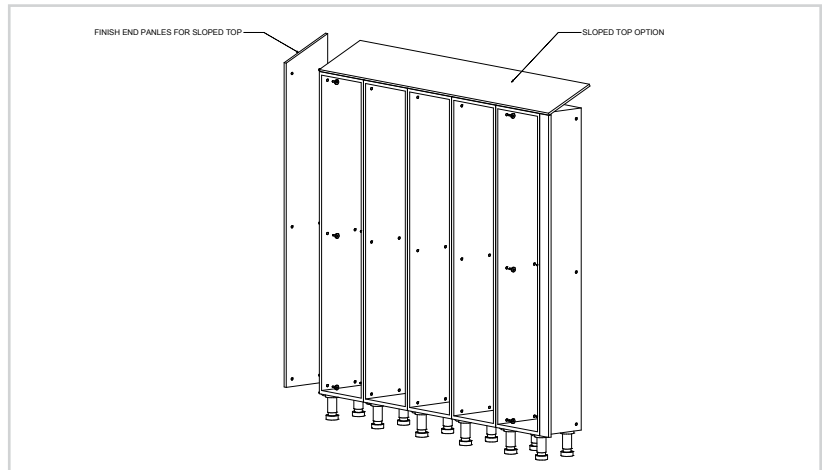

STEP FIVE – INSTALLING BASE PLATES

If lockers have adjustable ABS legs, then base plates (or kick plates) are provided. Base plates may need to be cut to length on site. If floors are of poor grade then base plates may have to be tapered to suit site conditions. Base plates are attached to locker legs with clips and adhesive mount which adheres to the backside of the base plate then easily clips on to the legs. It is optional to also add a short screw through the adhesive clip into the phenolic base plate.

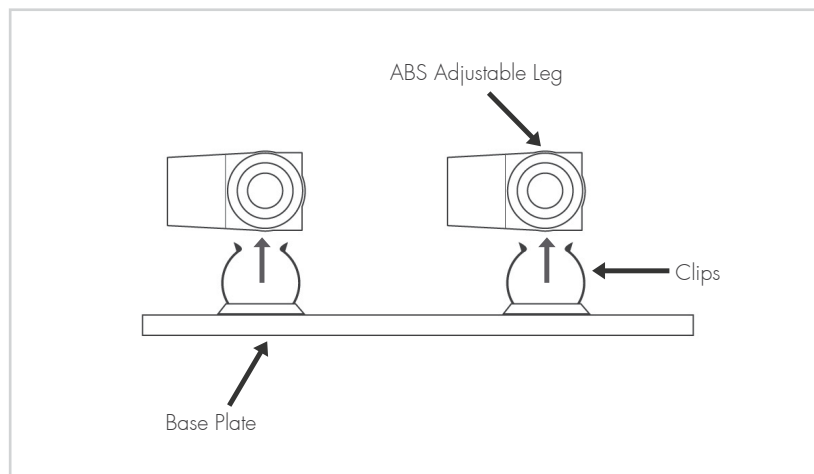

STEP SIX – INSTALLING SLOPED TOPS (IF SPECIFIED)

When installing the sloped tops, first the aluminum gussets must be in place. Start by installing one on each end (screws provided). When installing a large group of lockers, we suggest installing the gussets @ 32" apart. When all the gussets are in place and properly spaced, then panels can be installed (screws provided). The sloped top panels must have holes which needs to be drilled on site to fasten them to the gussets.

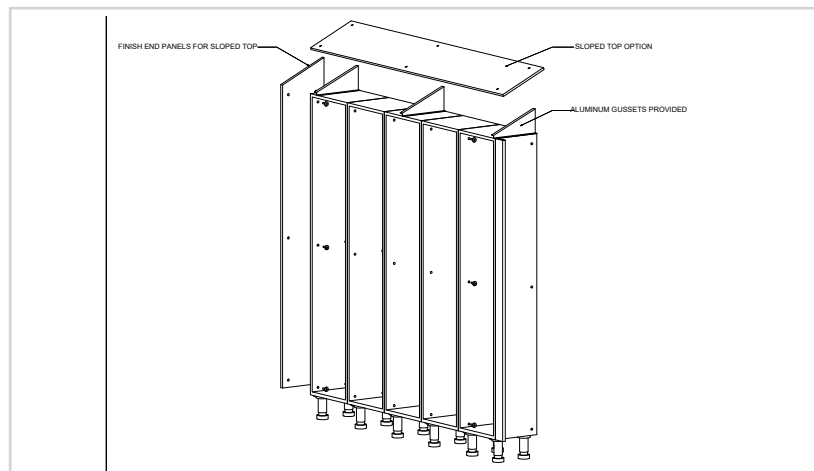

STEP SEVEN – INSTALLING DOORS (IF REQUIRED)

Installing the doors should be the last step when all components are in place. Start by installing the hinges on the doors by using the screws provided. After all doors are hinged you can now install the doors to the locker bodies by aligning the hinge holes to the locker holes and use screws provided. Door adjustments can be done by loosening the screws just a little, which allows the door to move up, down, forward and back. When you find the right alignment, then tighten the screws.

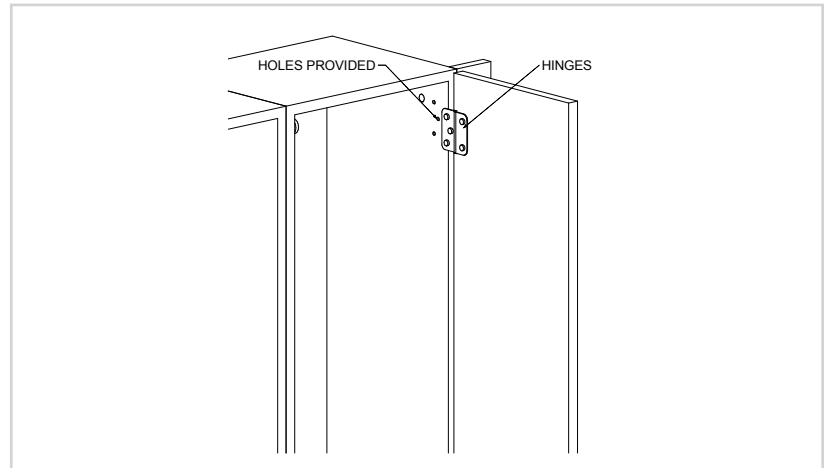

STEP EIGHT – INSTALLING NUMBER/ID PLATES (IF SPECIFIED)

Lockers are supplied with number/ID plates. These plates have a 3M adhesive backside and are to be placed in the pocket located in the face of the door. These numbers are to be in sequence with Architect/Designers plans.

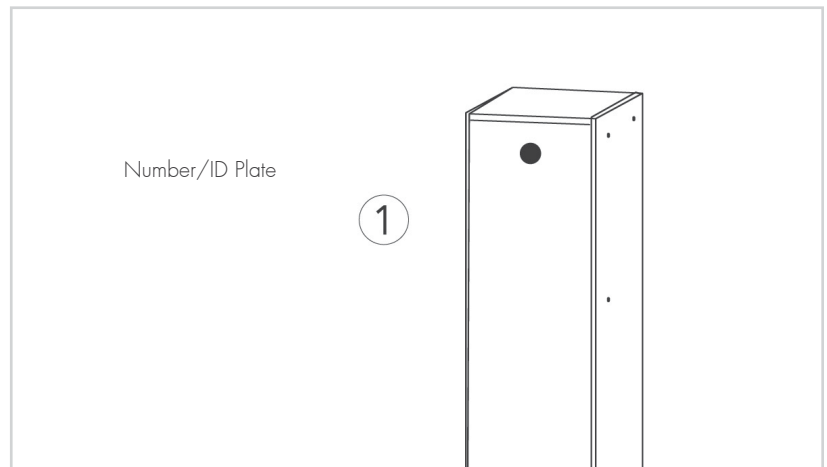

LOCKERS INSTALLED ON EXISTING BASE

First, make sure the existing base surface is leveled. Start by placing the first locker on the existing base and anchoring it before attaching the next locker. The locker base will have holes supplied to allow anchoring. Then follow step 2, 3, 4, (6 if specified), (7 if specified) & (8 if specified).

LOCKERS ARE NOW READY FOR FINAL DOOR & HASP ADJUSTMENTS AND CLEANING.

MADE IN NORTH AMERICA

Quality craftsmanship at competitive pricing.

REQUEST SPECIFICATIONS & SAMPLES

E: info@spectrumlockers.com

W: www.spectrumlockers.com

LOCAL REPRESENTATIVE